

# vector

## Adventure Aviation Takes Off!

Busting Wellington  
 Congestion in Westland National Park  
 Less Search, More Rescue





**4** **Adventure Aviation Takes Off!**

What you need to do to have your adventure aviation operation certificated under new Civil Aviation Rules, Part 115.

Photo courtesy of Skydive Lake Wanaka



**6** **Busting Wellington**

Airways reports there are two hotspots for airspace busts on the edges of the Wellington Control Zone, and things are at their worst during January. Take another look at your charts, and get your altitude right, or you'll be mixing it with the jets.



**12** **Congestion in Westland National Park**

With summer upon us there can be busy times in the tourist areas such as Franz, Fox, Cook, and Tasman. Lots of different aircraft in the air at the same time flying similar routes increases the risk of a mid-air collision.



**14** **Less Search, More Rescue**

A maritime disaster nearly 100 years ago led to the development of emergency radio beacons, and continuous evolution has given us today's 406 MHz versions and the associated space-based detection system. An overview of how it all fits together.

## In this issue...

New Flight Instructor Guide	3
Adventure Aviation Takes Off!	4
Busting Wellington	6
Bombing Run Close Call	8
Right Rails – Wrong Station	10
Security Threat Stopped	11
Congestion in Westland National Park	12
Less Search, More Rescue	14
Artex G-switch Update	17
Line Replaceable Unit (LRU)	18
New Authority Member	19
Director to Step Down	19
Keeping Threats and Errors on the Radar	20
Squawk for Safety	21
Bilateral Partners' Meeting	22
CAA Safety DVDs	22
IA Renewal Course	23
National Airspace and Air Navigation Plan	23
Aviation Safety Advisers	23
How to Get Aviation Publications	23
Planning an Aviation Event?	23
Accident Briefs	24
GA Defects	26
Summer Traffic Busy Spots	28

**Cover:** Ballooning is one of several activities covered by the new Part 115 *Adventure Aviation – Certification and Operations*. Photo: ©istock.com/seanfogg

### Published by

The Communications and Safety Education Unit of the Civil Aviation Authority of New Zealand, PO Box 3555, Wellington 6140.

Tel: +64 4 560 9400,  
Fax: +64 4 569 2024,  
Email: info@caa.govt.nz.

Published six times a year, in the last week of every odd month.

**Manager Communications** Bill Sommer.

**Editor** Peter Singleton.

### Safety Education Publishing Team

Alister Buckingham, Lakshmi Guda,  
Ken Mathews, Emma Peel, Anna Walkington,  
Rose Wood.

**Design** Gusto.

### Publication Content

Unless expressly stated as CAA policy, the views expressed in *Vector* do not necessarily reflect the policy of the Civil Aviation Authority. Articles are intended to stimulate discussion, and nothing in *Vector* is to be taken as overriding any New Zealand civil aviation legislation, or any statements issued by the Director of Civil Aviation, or the Civil Aviation Authority of New Zealand.

Reader comments and contributions are welcome and may be published, but the Editor reserves the right to edit or abridge them, and not to publish those that are judged not to contribute constructively towards safer aviation. Reader contributions and correspondence regarding the content of *Vector* should be addressed to: *Vector* Editor, PO Box 3555, Wellington 6140, or email: info@caa.govt.nz.

### Free Distribution

*Vector* is distributed automatically to all New Zealand flight crew, air traffic controllers, aircraft maintenance engineer licence holders, aircraft owners, most organisations holding an aviation document, and to certain other persons and organisations interested in promoting safer aviation.

In the case of flight crew and air traffic controllers, a current aviation medical certificate must be held, and a current New Zealand address given, to ensure magazine entitlement.

Holders of Pilot Certificates issued by Part 149 certificated organisations can also apply to receive a free *Vector* (see the CAA web site for details). *Vector* also appears on the CAA's web site: www.caa.govt.nz.

### Change of Address

Readers receiving *Vector* free of charge should notify info@caa.govt.nz of any change of address, quoting your CAA Client Number. Paying subscribers should notify The Colour Guy.

### Paid Subscriptions

*Vector* is available on subscription only from The Colour Guy, PO Box 30464, Lower Hutt 5040, Freephone 0800 438 785.

### Copyright

Reproduction in whole or in part of any item in *Vector*, other than material shown to be from other sources or named authors, is freely permitted, providing that it is intended solely for the purpose of promoting safer aviation, and providing that acknowledgment is given to *Vector*.



# Flight Instructor Guide

Available free in an exciting new format for easy online use.



[www.caa.govt.nz/fig](http://www.caa.govt.nz/fig)

As well as using the Guide online, you can...

» Download each briefing.

[Click here to download Briefing PDF](#)

» Download each whiteboard layout.

[Click here to download Whiteboard PDF](#)

» Download the diagrams for each briefing.

[Click here to download Diagrams](#)

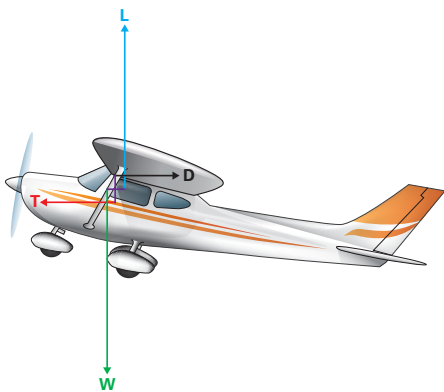

But wait, there's more! You can also download:

» All the briefings at once.

[Click here to download All briefing PDFs](#)

» All the whiteboard layouts at once.

[Click here to download All whiteboard PDFs](#)

» All the diagrams at once.

[Click here to download All diagrams](#)

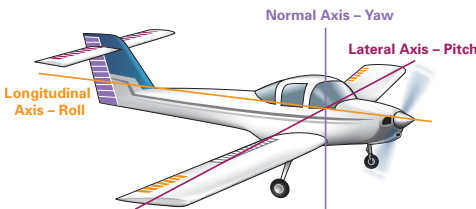

A comprehensive suite of diagrams will help instructors create customised and professional briefing presentations.

The guide has been reordered and divided into four sections for ease of use: Basic Concepts, Circuit Training, Advanced Manoeuvres, and Instrument Flying. Existing content has been updated, and Terrain & Weather Awareness, Basic Mountain Flying, and Night Flying have been added.

If you would like a complete printed version of the guide, you can purchase it from The Colour Guy by calling 0800 GET RULES (0800 438 785), or emailing [orders@colourguy.co.nz](mailto:orders@colourguy.co.nz) – it's only \$61.93 plus postage and packaging.



[Click here to view Instructions](#)

Make sure you read the instructions before using the guide. ■

# Adventure Aviation Takes Off!

“In a Part 115 operation, the thrill or risk aspect of adventure aviation should be a perception in the mind of the buyer, not an actual risk,” says CAA’s General Manager General Aviation, John Lanham.

## Part 115 – A Step by Step Guide to Certification

New Civil Aviation Rules, Part 115 *Adventure Aviation – Certification and Operations* came into effect 10 November 2011.

An adventure aviation operation involves carrying passengers for hire or reward, where the purpose of the operation is for the passenger’s recreational experience of participating in the flight, or engaging in the aerial operation.

This includes hot air ballooning, gliding, tandem hang glider and paraglider operations, tandem parachute descent, and parachute-drop aircraft operations (if not already conducted under a Part 119 AOC). It also applies to A to A flights (those that take off and land in the same place) in aircraft issued with certain special category airworthiness certificates (Primary, LSA and Limited); A to A flights in an aircraft issued with a standard category airworthiness certificate conducting formation flight, aerobatic manoeuvres, and similar non-standard flight manoeuvres, such as steep climbs, steep descents and steep turns; and A to A flights in Class 2 microlight aircraft.

## Getting Started

Under Part 115, all adventure aviation operators must hold an Operator Certificate.

For those currently operating under Parts 101, 103, 104, 105, and 106, here are the transition timeframes for gaining a Part 115 Operator Certificate:

- » Hot air balloon, hang glider, paraglider, tandem parachute, and parachute drop aircraft operators must be certificated by 1 May 2012.
- » Microlight aircraft operations must be certificated by 1 November 2012.
- » Glider operations must be certificated by 1 May 2013.

Those currently conducting an adventure aviation operation under a Part 119 AOC may continue to do so until the expiry of that certificate, or 10 November 2012, whichever comes first.

The AOC application process takes time. How long depends on the accuracy of the information supplied in your application, and the complexity of your operations. Plan to achieve certification early. Applications made at the last minute cannot be processed in time to meet the certification cut-off dates.

New adventure aviation operators (including warbirds) must be certificated under Part 115 before starting operations.

## How to Apply for an Operator Certificate

1. Decide on the scope of your adventure aviation activity.

Will your organisation be conducting one type of activity (for example, gliding), or multiple activities, such as microlight flights and special category aircraft operations?

2. Identify appropriate senior persons for your organisation.

Each senior person must complete a Fit and Proper Person form (24FPP) and provide the following supporting documents:

- » A Curriculum Vitae.
- » Proof of identity.
- » Proof of address for service.
- » Criminal Record History from the Ministry of Justice.
- » Offence History Report from Land Transport New Zealand.

Plan ahead, because it can take three to four weeks to obtain these reports.

3. Complete form 24115/01 – *Application for Issue, Renewal, or Amendment of an Adventure Aviation Certificate under Civil Aviation Rules, Part 115*, making sure you follow the instructions on the form.
4. Develop a company exposition using the Part 115 Compliance Matrices developed by the CAA to assist applicants.

Compliance Matrix 24115/02 contains the operating and certification rules common to all types of adventure aviation operations. This must be used in conjunction with the matrix for the specific type of operation you will be conducting: hot air balloon (24115/02I), parachute-drop aircraft (24115/02J), tandem parachutes (24115/02K), gliders (24115/02L), hang gliders and paragliders (24115/02M), special category aircraft (24115/02O), or microlight aircraft (24115/02P).

Matrices are designed to speed up the certification process by ensuring every applicable rule requirement has been addressed in your exposition. If required policies and procedures can be located in your exposition quickly, this will reduce the cost of certification.

5. Submit your application to the CAA.

Send everything in at the same time: application form 24115/01, your exposition and completed compliance matrices, 24FPP forms and supporting documentation for each nominated senior person.

6. Prepare for a CAA site inspection.

Ensure that all aircraft and personnel documentation is available and up to date, and that senior persons are available to be interviewed. Your senior persons should fully understand the company exposition, and the responsibilities of their role contained in the exposition.

Civil Aviation Rules and all CAA forms can be found on the CAA web site, [www.caa.govt.nz](http://www.caa.govt.nz). If you have any questions while preparing your application, contact the Sport and Recreation team at the CAA for advice and assistance: Email: [info@caa.govt.nz](mailto:info@caa.govt.nz), or Tel: 04 560 9400. ■

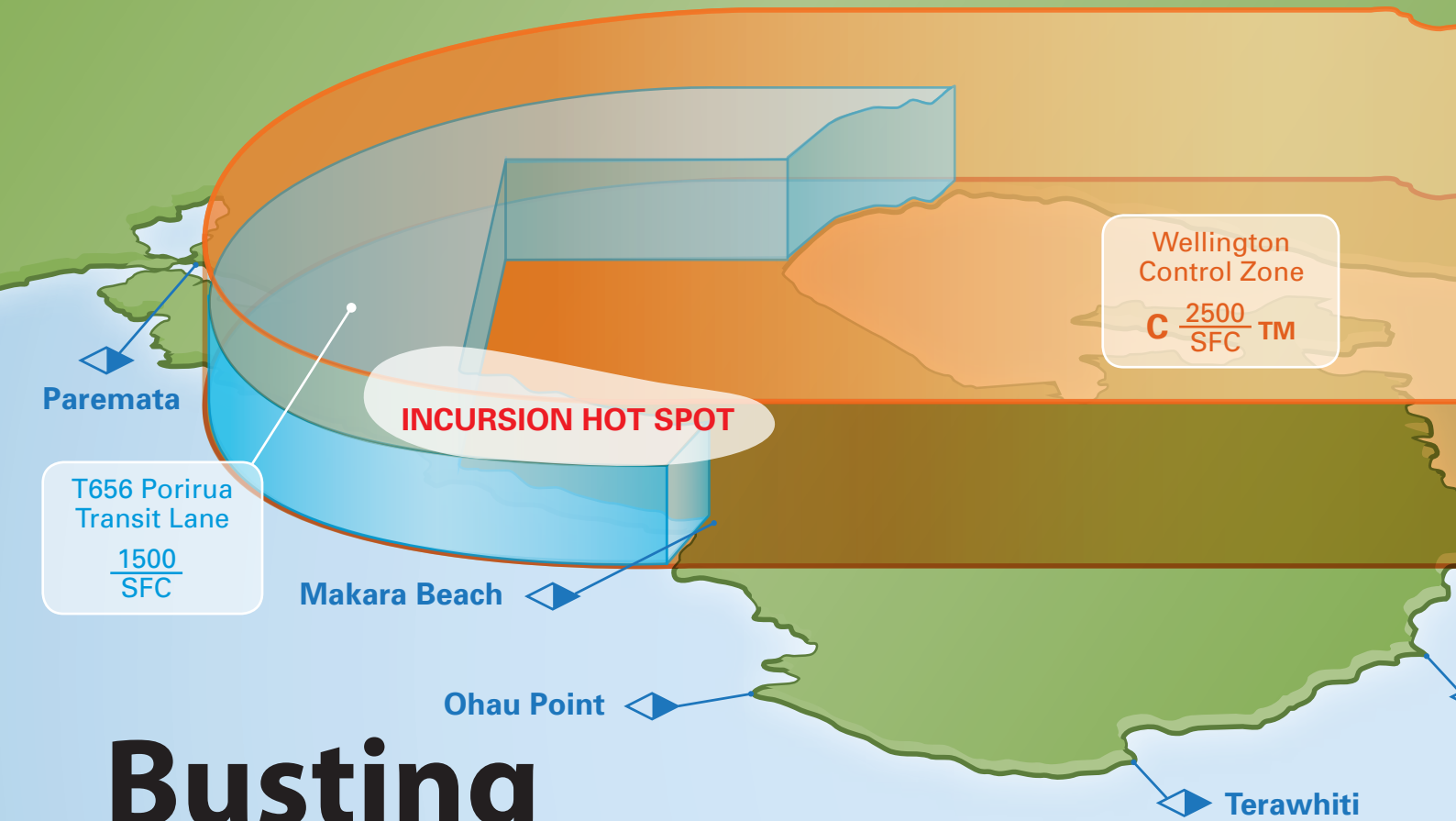

# Busting Wellington

Each summer, light VFR aircraft bust airspace around the Wellington Control Zone. In two particular hot spots, they risk “an unwelcome encounter with an A320”.

**A**irways National Air Safety Incident Controller, Andrew Aldridge, began studying airspace infringements in the Wellington Control Area after controllers noticed an increase in airspace busts. Since then, Airways recorded seven airspace infringements in January this year, and a total of 21 in 2011 so far.

By plotting these infringements, Andrew has identified two main areas where VFR pilots are getting it wrong.

“The VFR transit lane T656 that wraps around the top of the Wellington Control Zone is available only from the surface to 1500 feet. Go any higher than that and you are conflicting with IFR traffic. It only takes one infringing aircraft to have an unexpected encounter with an A320 and we have a serious incident on our hands.”

Airways’ Approach Controller, Martin Foster, agrees the risk is real.

“Aircraft tracking along the coast from Paraparaumu can be at 2500 feet at Titahi Bay, but they can’t just carry on at that

height through the VFR transit lane, they’ve got to descend to 1500 feet, or get a clearance to enter the Control Zone.

“That’s because IFR traffic for runway 16 is approaching from the north, and we let them descend to 2000 feet in that area because we know the VFR traffic should be down under 1500 feet,” Martin says.

Another area collecting busts is down on the south-east corner of the Control Zone between Baring and Turakirae, and out to sea inside the Control Area.

Andrew Aldridge says those busts are typically from pilots transiting across Cook Strait.

“There’s a tendency when transiting from Turakirae Head to Cape Campbell, to cut off the corner of the control zone.

“That area’s important because it’s right next door to the arrival and departure fan for IFR aircraft down to 1500 feet, and it’s also bordered by the instrument sector of the control zone, where jets are descending unrestricted.

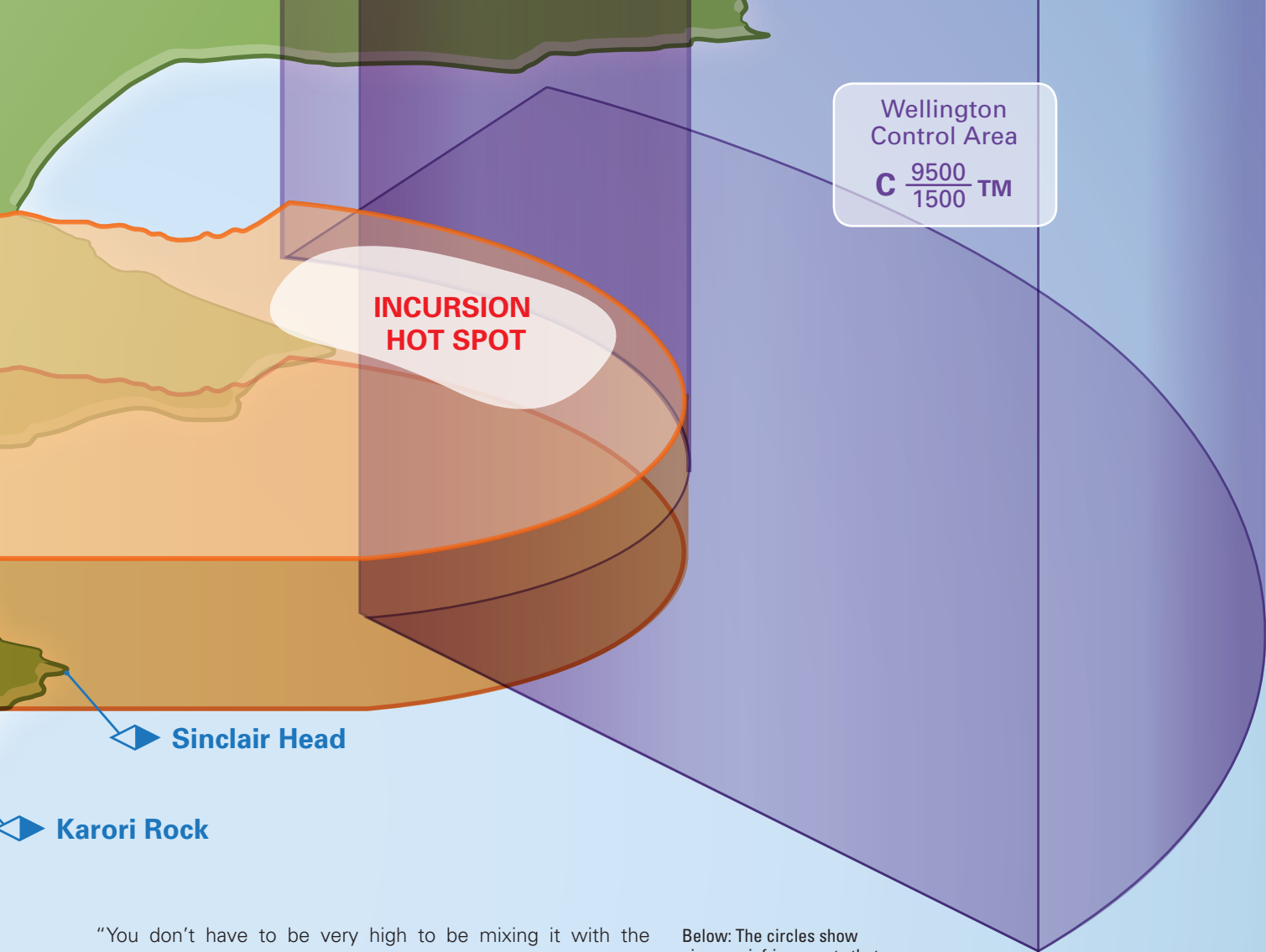

Wellington  
Control Area  
C 9500 / 1500 TM

**INCURSION  
HOT SPOT**

▶ Sinclair Head

▶ Karori Rock

“You don’t have to be very high to be mixing it with the jets there.

“We know that when you’re out there, navigating is a hard thing to do sometimes. There are no lines painted in the sky, and most people are trying to do the right thing. But if you don’t want to ask for a clearance, you’ll need to head out to sea a bit further to remain clear of the control zone, and stay under 1500 feet.”

Martin Foster says Wellington’s Approach Controllers know the Cook Strait can be daunting, and says they are very happy to help VFR aircraft out with radar monitoring. This is a free service.

“If a VFR pilot is crossing Cook Strait, they can get a clearance from us to transit at 3000 or 4000 feet, or we can just provide radar monitoring.”

To request radar monitoring, call Wellington Control on 122.3, and let them know where you want to go. They will identify you, and then track your progress across the Strait.

“We’re really happy to do this, and will only say it’s not available if we’re really busy with IFR traffic,” Martin says.

“We’d much rather that, than have an aircraft infringe the Control Zone, which could turn into a serious problem. If necessary, we’ll suggest a heading to assist.”

Once you are being radar-monitored, the controllers will observe your track, and help keep you in the right place at the right height. Remember though, that a clearance or monitoring from Wellington Control is not a clearance into the control zone, for which you must call the tower on 118.8.

Below: The circles show airspace infringements that are clustered in two hot spots.



“It’s a pretty scary piece of water to go across. If I was out there, I’d like to think someone was keeping an eye on me,” Martin says.

“Probably, the best thing pilots can do is sit down and brief properly before the flight. Study the charts before you set out. But if you get stuck, talk to us. We’re here to help.” ■

# Bombing Run Close Call



A GA pilot put his aircraft in extreme danger by flying through an active Military Operating Area while an Orion was conducting bombing runs. RNZAF Flight Safety Officer, Squadron Leader Rachel James, reports on this incident.

**O**n the morning of 28 February 2011, an Orion commenced bombing runs at the Kaipara Air Weapons Range. This is within Military Operating Area (MOA) M106. The Orion was releasing its bombs at 1250 feet amsl. Partway through the bombing run, the Range Control Officer (RCO) spotted a light aircraft approaching from the north at approximately 1500 feet. The RCO advised the Orion of the potential conflict, and the Orion responded by ceasing bombing activity, and climbing immediately to 3000 feet, in order to gain positive separation from the incoming traffic. The Orion's radar operator tracked the light aircraft as it transited straight through M106, vacating along the beach to the south. Fortunately, that was the extent of the 'Flight Safety Event' – an incursion by a civilian aircraft operator into an active military operating area. No one was hurt, and nothing was damaged.

I hope you agree, in this case, the light aircraft operator was very lucky – lucky

the RCO was on the lookout; lucky the Orion was quick to take evasive action; lucky the Orion wasn't closer to the "drop" element of the bombing run; lucky the Orion aircrew displayed a high level of situational awareness and turned what was a potentially dangerous conflict into a benign, non-event. The result could have been so different.

## What are the Risks?

We conduct many activities at Kaipara. These include bombing, flares, helicopter gunnery, surface-to-air missile firing, explosive ordnance disposal, and simulated surface-to-air rocket attacks as part of tactical flying exercises.

Shockwaves disrupt airflow, and could result in an unintended deviation from your aircraft's attitude and flight path. It is possible your aircraft structure could be damaged by impact with a falling munition, or more likely, damaged by fragmentation from an exploding bomb. Bomb fragments can be quite large (the

length of a forearm) and can also travel quite far (6500 feet is our safety distance). There is also the possibility of distraction due to the bright flash of an exploding bomb or flare and sand particles being kicked up into the air.

## What Went Wrong?

Why would a civilian light aircraft fly through an active MOA? Surely the operator wouldn't have chosen this particular flight path if they had been aware of the danger. So why didn't they know? One can only assume they had omitted a vital pre-flight planning step – checking NOTAMs and *AIP New Zealand Supplements* prior to getting airborne.

Checking NOTAMs and *AIP Supplements* is as important as checking the weather, the map, the fuel and the aircraft. NOTAMs detail the establishment of, condition of, or any change in aeronautical facilities, services, procedures or hazards, where the timely knowledge of this is essential to pilots.



NOTAMs are issued by Airways via internet, fax, telephone, and AFTN. Going flying without this essential knowledge is not a sensible option – you put yourself and other airspace users in danger. NOTAMs only offer protection if aviators read them. Otherwise, they are worthless notifications. In this case, a NOTAM was in place, activating M106 from the surface to Flight Level 150. It is also important to check the *AIP Supplements*, as temporary special use airspace can be published there.

The MOAs covering the Kaipara Air Weapons Range, M103 and M106, are Class G airspace below 4500 feet for the portion south of South Head Point, and below 6500 feet for the northern portion. The airspace is not transponder mandatory, and radar coverage and communications are intermittent below 2500 feet. Both MOAs are activated by

NOTAM, so sometimes it is perfectly legal and safe to fly through them. However, when they are active, they are definitely not safe airspace! Rule 91.133 states that a pilot must not operate an aircraft within a MOA, unless they have approval from the administering authority. This is to prevent exposure to a very real risk.

### Safety First

Prior to conducting live bombing runs, military aircraft like the Orion have several options available to ensure the area is clear of other traffic. The Orion gains an entry clearance from ATC, who also provide traffic information. In this case, there was no reported traffic. The Orion aircrew then search for other aircraft transponders using their onboard radar and optics. Observers are also positioned specifically as lookouts, using

their 'Mk 1 eyeballs'. These checks are over and above the issue of the NOTAM – which is intended to keep other aircraft out of the MOA. From a military perspective, nothing further could have been done to prevent this situation – a NOTAM was issued, traffic information was sought, an RCO was in place, radar, optics and on-board observers were used. Luckily, the infringing traffic was spotted in time to avoid a more serious incident.

I hope this close call has raised awareness within the general aviation community of the risk associated with flying through active military operating areas – not only in Kaipara, but also around Waiouru and in the Manawatu. It really isn't worth the risk. Don't be a statistic – check NOTAMs before you launch. Safe flying everyone. ■



# Right Rails – Wrong Station

Line up, open the throttle, accelerate,  
seat unlocks, whoa!

There will be quite a number of pilots who have had this experience in an older Cessna single – sometimes the result has been no more than a big fright, and other times, fortunately very few in New Zealand, an accident has ensued. The effect is much more pronounced in the tailwheel 180 and 185, as the acceleration force has a gravity-assisted head start while the aircraft is in the three-point attitude. Generally, the only things to hang on to are the control column and the throttle, and pulling these back at the same time can have a disastrous effect on further flight.

When we climb aboard our Cessna, we pilots need to slide the seat rearwards in order to get our legs past the doorpost, and once seated, we haul the seat forwards to our normal flight position and let the locking pins engage with the holes in the seat rails. This is usually followed by a wriggle to ensure the seat is actually locked.

Over time, however, the holes in the seat rails become worn, and what seemed initially to be a secure seat can let us down at the worst possible moment. 'Sit back and relax' definitely doesn't apply here! Not only can the holes become worn, but also the rails

themselves, the rollers, roller housings and tangs. Lack of maintenance, wear and tear, and well-intended but detrimental lubrication all play a part. The reason for not applying lubricant to the moving parts is that it will attract dirt and dust, making a 'grinding paste' that will accelerate wear rather than preventing it.

The CAA has an Airworthiness Directive (AD) in force for each affected Cessna model; this in turn refers to the requirements of FAA AD 2011-10-09, which came into effect on 17 June 2011, superseding AD 87-20-03. The AD calls up a 100-hourly inspection, cleaning and measurement of the relevant components, and prescribes the allowable wear limits.

On 14 May 2007, Cessna issued Service Bulletin SEB07-5 *Pilot and copilot secondary seat stop installation*, with compliance required within the next 200 hours of operation or 12 months, whichever occurred first. The installation consists of an inertia reel assembly fixed to the seat frame, with the free end of the belt bolted to the floor. The release cable is connected to the seat stop release, so that the locking pins and inertia reel lock are released simultaneously. In the event of a seat unlocking, the inertia reel will prevent its moving any appreciable distance. Cessna provided for the reimbursement

of the cost of parts and fitting, provided that it was done under warranty claim, and by 14 May 2009, later extended to 17 December 2009 by Revision 1.

This deadline has now been extended to June 2012, so the opportunity still exists for owners of affected models to take advantage of the offer, which is conditional on being performed by an approved Cessna repair station. Although Cessna has designated the SB 'mandatory', this has not been carried over into AD action. Owners of affected models who are contemplating having the secondary stop installed should discuss the process with their Cessna agent sooner rather than later, as there will be a certain amount of lead time required to obtain the parts. ■



# Security Threat Stopped

On 17 September 2011, a man dressed as a pilot attempted to talk his way into the security area of Auckland International Airport.



Photos courtesy of Auckland International Airport Limited

The man approached Customer Service Agents at the Air New Zealand Link gates in the domestic terminal and asked for airside access. When airline staff asked to see his airport ID card, the man claimed he had left it in a plane on the tarmac. Staff continued to refuse the man access without the appropriate ID.

Thanks to excellent work by the Customer Service Agents involved, this security threat was stopped in its tracks, and six men have since been arrested and charged over the incident.

Airport security is no longer just the responsibility of security officials – it is everyone's business. From pilots, to taxi drivers, and everyone in between: airport company staff in the car park, café and retail workers, airport cleaners, and all airline staff.

A lot of work has gone into building a strong security culture at New Zealand's airports. As a result of the 2008 Domestic Security Review, the government tasked CAA and Avsec with setting up Security Awareness Groups at all regional airports with scheduled passenger services. This process was completed in December

2010, and meetings have been well attended by aerodrome stakeholders, tenants, and local police. Some groups have even held two or three meetings since their inception.

Due to the Rugby World Cup, Security Committee Meetings at New Zealand's security designated aerodromes have been held twice so far this year, to ensure that all participants are fully aware of their security obligations. This has resulted in good planning and communication between groups.

As an airport employee, you will know your environment better than anyone else. If you see something unusual, pay more attention to it. It may be a car parked in the same place for a few days in a row – take a good look at the person in the car, note down the registration number, and report the details to airport management. That person could be watching aircraft movements and trying to plan something.

Police who attended the security awareness group meetings said they want to hear about suspicious cars or people, so they can be proactive rather than reactive.

*A strong security culture will protect operators against the threat of a terrorist attack, or the actions of an acutely disaffected person.*

Building an effective security culture at GA aerodromes is also very important. Avsec have travelled to a number of these and held meetings with local operators to discuss the security of buildings and aircraft on the aerodrome. These initiatives have been well received by the GA community.

A strong security culture will protect operators against the threat of a terrorist attack, or the actions of an acutely disaffected person. Security awareness training for staff is an essential element of preventative security. Recent events have shown that airport staff are doing an excellent job. ■

# Congestion in Westland

## Busy times around Franz, Fox, Cook and Tasman

Summer is here, the weather is fantastic and it isn't dark till late. Those buses have just pulled up and the tourists all want to go on a scenic flight, now please. What could be better?

Great for business, but all those tourists and good weather mean lots of aircraft in the air at the same time, flying similar routes, and looking at the same scenery.

Summertime brings with it large numbers of helicopters and aeroplanes operating on scenic flights in the congested confines of Westland National Park, especially up and over the glaciers and névés, and around Mounts Cook and Tasman.

Add to the mix the transient pilots that summer brings, wanting to fly through the area or do private scenic flights, and you begin to picture the emerging scene.

## Safety Issues

Merv Falconer, CAA Manager Fixed Wing and former Mount Cook ski-plane pilot, says it is a concern that with up to 30 or more aircraft in the air at any given time in the same confined area, there is always the potential for a mid-air collision. There is the possibility also of the unwary operator, particularly those unfamiliar with the area, getting caught in a severe downdraught or turbulence, which at best can be upsetting for the passengers, and at worst can lead to tragedy.

"The mixing of aeroplanes and helicopters can create conflicts. The various operators and pilots need to be aware of how busy the area can be, and be aware of the diverse flight paths flown by the two types, and have strategies in place to mitigate the risks.

"Aeroplanes tend to fly more set patterns, whereas helicopters can climb and descend rapidly to get into and out of the area in the limited time available. Helicopters change altitude quickly, sometimes as fast as 1500 feet per minute, because of their tight flight schedules," Merv cautions.

Merv advises that succinct, clear, and accurate radio position calls at appropriate times are an essential element for safe flight in the area, as well as pilots listening out and forming a continuous mental picture of where the other traffic is.

"Radio congestion can be an issue, and radio chatter can at times be non-stop and therefore be daunting to a transient pilot, or to those new to the area," Merv says.

"Radio calls on the local frequency at frequent intervals are nevertheless important and should include the aircraft type (for transient aircraft only, on the first call), position at known landmarks, height, direction and intentions.

"Because aircraft may be in valleys or on the opposite side of the Main Divide, not all pilots will hear the various radio calls, and frequency jamming can occur. Simply making a radio call doesn't guarantee that all pilots will have heard it.

"Pilots should make their calls before entering the Southern Alps Mandatory Broadcast Zone (MBZ) and at regular frequent intervals in the MBZ. Also, call before crossing passes or the Main Divide.

"A thorough lookout is essential, and a good idea is to ask your passengers to keep a lookout and to alert the pilot if they spot any nearby traffic."

The established operators mostly belong to the local area user group – The Mount Cook and Westland National Park Resident User Group. Regular group meetings are held and the operators follow the group's documented procedures as a means of



# National Park

helping to manage the risks and reduce the potential for a collision. For example, when climbing and descending all aircraft will stay on the right side of the valleys, unless wind or turbulence makes this unsafe, and pilots will transmit frequent concise radio position calls.

Tim Rayward is Chairman of the user group and Operations Manager for Air Safaris Limited, which operates scenic sightseeing tours from three locations surrounding Mount Cook: Lake Tekapo to the east of the Southern Alps and Main Divide, Glentanner Park situated just east of the Main Divide and near Mount Cook village, and Franz Josef Glacier west of the Main Divide.

“Traffic can be very busy particularly in the lower levels from around Fox and Franz Josef townships, east up to the head of the glaciers and the névés,” Tim advises.

He cautions that skydiving activities also occur frequently around Franz and Fox aerodromes, and to the west, adding to the traffic congestion.

“Fox Glacier can have the worst traffic and can get very busy, because it is near Mount Cook and Mount Tasman.

“An altitude split is the surest way of ensuring safe separation, particularly when unsure of the exact position of other traffic. This is relatively easy with fixed-wing traffic tending to maintain consistent levels. However, local helicopters are likely to climb and descend rapidly over a wide range of altitudes up to and above the height of Aoraki Mount Cook. It is really important that pilots climbing or descending make this clear in their position reports, so other traffic is aware that those pilots are not maintaining the last reported altitude.

“The busy season is from about mid-October through to the end of March. The busy time of each day is from mid-morning to early afternoon, especially during the middle of the day, although often at Franz and Fox the early morning and late afternoons can be busy,” Tim advises.

## Some Precautions

Tim recommends that pilots check ahead and identify the traffic hot spots.

“If you are planning on using the local aerodromes, which are mostly private, then you will need permission from the operators who will be happy to brief pilots before coming to the area.

“Be aware of the requirements of the MBZ. Make position reports relative to specific geographical features for easy reference. Report frequently, say every five minutes, and have a good clear radio that works. If you haven’t heard anything for a while, then check your radio. If it’s quiet in the area, then don’t relax and let your guard down. Maintain a good lookout because there have been some close calls when it seemed quiet.

“Itinerant pilots can avoid the heavy traffic by planning their scenic flights for later in the day to take advantage of the longer daylight hours and the fantastic views that are available at that time of day. Maintaining plenty of distance back from the main features gives manoeuvring room and reduces the likelihood of coming into conflict with the local traffic.

“Pilots can avoid the traffic hot spots by transiting at higher levels at or above 10,000 feet and remaining slightly wide of the divide when on the western side.

“Remember to avoid flying over towns, and that noise abatement or other local procedures may also apply.”

Tim says that Air Safaris encourages those pilots unfamiliar with the area to come and talk to them, and to first go on a familiarisation flight with a local pilot, if the opportunity arises.

## Read On

GAP booklet, *In, Out and Around Mount Cook*.

NOTAMS and *AIP Supplements*.

*AIP New Zealand* ENR 1.16 para 1.9.

*AIP New Zealand, Vol 4, AD*, relevant aerodrome information.

Relevant aeronautical charts available from Airways Corporation.

Refer to the back cover of this *Vector* for “Summer Traffic Busy Spots”. ■



# Less Search, More Rescue

Early emergency beacons worked largely on the 'wait-and-hope' principle, but the current beacons and supporting infrastructure have removed most of the waiting and hoping.

Emergency beacon history has its roots in the *Titanic* disaster, which resulted in the development of emergency transmitters for carriage on ships' lifeboats. These operated on 500 kHz, and through successive modernisations, could still be found in use up to the early 1970s. VHF beacons evolved during World War II, and compact versions were developed for aircraft life raft use.

Post-war developments saw the adoption of 121.5 and 243 MHz as the respective civil and military aeronautical emergency frequencies, and the production of aeronautical and marine beacons designed to transmit on either or both. Mandating the carriage of beacons on aircraft started in 1968 in the USA, with some states pre-empting the 1970 Federal legislation that required compliance by the end of 1973. New Zealand required the carriage of "fully operative emergency aircraft locator beacons" from 1 January 1986, although there had been a limited requirement in the regulations from 1979.

These beacons relied on their signal being detected by an overflying aircraft listening on 121.5 MHz, so for a survivor, it was very much 'wait and hope'. Unless their aircraft was on a flight plan or other form of flight following, the time taken to organise a search could well exceed the endurance of the beacon battery.

A cooperative programme began in 1979, with the signing of a memorandum of understanding between agencies of the former USSR, USA, Canada, and France. This saw a satellite-based alerting system declared operational in 1985 – the Cospas-Sarsat system, which detected beacon signals on 121.5 and 243 MHz, and relayed their approximate position to earth stations. Progressive enhancements of the satellite system to provide improved coverage and to process the newer 406 MHz beacon signals has taken place since the system was introduced, and in 2009, the 121.5/243 processing capability was withdrawn.

Today, the Cospas-Sarsat system comprises three segments – radio beacon, space, and ground, and each is described in turn.

## Radio Beacon

There are three main types of beacon: aviation (emergency locator transmitter or ELT), marine (emergency position indicating radio beacon or EPIRB) and personal locator beacons, or PLB. The carriage of automatic ELTs in aircraft is mandated by rule 91.529, and rule 91.525 requires the carriage of an EPIRB or survival ELT on certain over-water operations.

Beacon details must be registered (rule 91.529(f)) with RCCNZ, and updated whenever ownership changes or when a beacon is moved to a different aircraft. Up-to-date details will avoid delays in contacting the owner or operator in the event of a beacon activation.

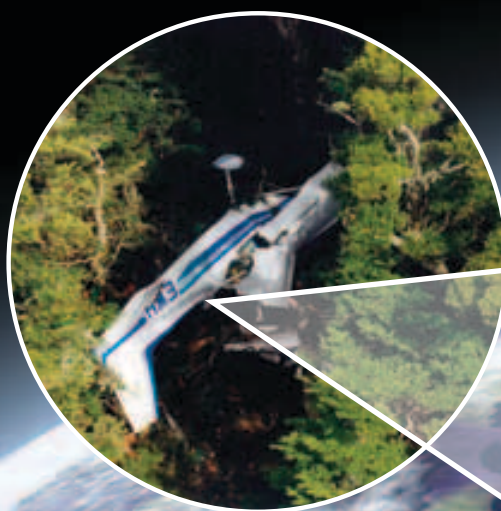

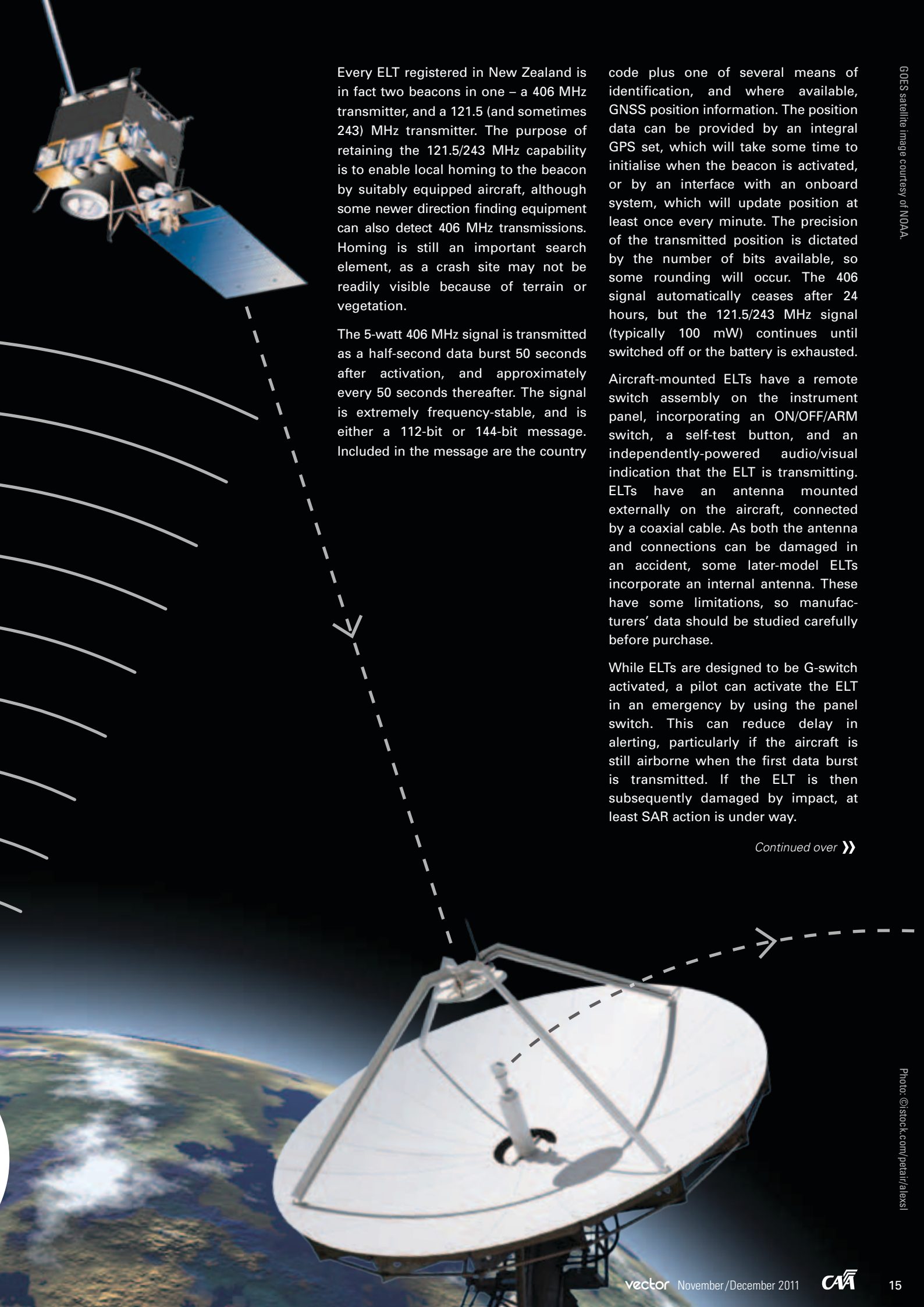

Every ELT registered in New Zealand is in fact two beacons in one – a 406 MHz transmitter, and a 121.5 (and sometimes 243) MHz transmitter. The purpose of retaining the 121.5/243 MHz capability is to enable local homing to the beacon by suitably equipped aircraft, although some newer direction finding equipment can also detect 406 MHz transmissions. Homing is still an important search element, as a crash site may not be readily visible because of terrain or vegetation.

The 5-watt 406 MHz signal is transmitted as a half-second data burst 50 seconds after activation, and approximately every 50 seconds thereafter. The signal is extremely frequency-stable, and is either a 112-bit or 144-bit message. Included in the message are the country

code plus one of several means of identification, and where available, GNSS position information. The position data can be provided by an integral GPS set, which will take some time to initialise when the beacon is activated, or by an interface with an onboard system, which will update position at least once every minute. The precision of the transmitted position is dictated by the number of bits available, so some rounding will occur. The 406 signal automatically ceases after 24 hours, but the 121.5/243 MHz signal (typically 100 mW) continues until switched off or the battery is exhausted.

Aircraft-mounted ELTs have a remote switch assembly on the instrument panel, incorporating an ON/OFF/ARM switch, a self-test button, and an independently-powered audio/visual indication that the ELT is transmitting. ELTs have an antenna mounted externally on the aircraft, connected by a coaxial cable. As both the antenna and connections can be damaged in an accident, some later-model ELTs incorporate an internal antenna. These have some limitations, so manufacturers' data should be studied carefully before purchase.

While ELTs are designed to be G-switch activated, a pilot can activate the ELT in an emergency by using the panel switch. This can reduce delay in alerting, particularly if the aircraft is still airborne when the first data burst is transmitted. If the ELT is then subsequently damaged by impact, at least SAR action is under way.

*Continued over >>*

Test requirements are detailed in rule 91.606(e)(4) and Part 43, Appendix F, and must be done in accordance with manufacturers' instructions. Note that the beacon self-test sequence includes the transmission of one 406 MHz burst, formatted so that it will not be processed, and a short transmission on 121.5/243 MHz. Part of the self-test checks the radiated signal strength of each frequency. The 121.5 MHz signal can also be monitored by listening on one of the aircraft VHF sets. Each self-test is a draw on the battery, so should be done only at the specified intervals. 'Live' testing of an ELT must be avoided.

Should a beacon be operated inadvertently, it should be turned OFF (or to ARM) as soon as it is noticed, and RCCNZ or the nearest ATS facility informed. There is no penalty for reporting an inadvertent activation, but failure to do so can result in a costly SAR operation. Anyone installing an ELT must make sure the ELT is registered **before** installation (see AC43-14, Appendix 2) and should also contact RCCNZ to advise them of the hex or UIN code of the beacon in case of inadvertent activation.

## Space Segment

The Cospas-Sarsat system comprises two types of satellite: GEOSAR, in geostationary orbit, and LEOSAR, in low polar orbit. These are not dedicated SAR satellites, but are 'payloads' on meteorological satellites.

The five GEOSAR satellites orbit the earth above the equator, at an altitude of 35,786 km. Their orbit period is 24 hours, and because they orbit in the same direction as the earth's rotation, they appear stationary relative to the earth's surface. The 'field of view' of these satellites is approximately one third of the globe, between about 70 degrees north and south. Coverage of New Zealand is provided by GOES-11 (or GOES-West), at 135 degrees west. The Sarsat package is simply a 406 MHz repeater.

The LEOSAR, or low earth orbit, constellation consists of Sarsat payloads on five NOAA satellites (-15 to -19), and METOP-A. These are in near-polar orbit between 810 and 856 km, with a period

of about 100 minutes, and their field of view is a 'swath' about 4000 km wide. The Sarsat equipment on the LEOSAR satellites is a Search and Rescue Processor (SARP), which processes the digital data from the beacon signal, and a Search and Rescue Repeater (SARR).

An enhancement of the space segment under development is the MEOSAR system. The addition of SAR payloads to GPS, Glonass and Galileo navigation satellites in medium earth orbit will greatly improve coverage and response times, and has been undergoing 'proof of concept' since 2006. Although there are nine trial SAR payloads in orbit, the first 'live' unit was launched in February 2011, on a Russian Glonass K satellite. All future GPS, Glonass and Galileo satellites will have a SAR payload, so all three constellations will ultimately be fully equipped. These satellites orbit between 20,000 and 22,000 km, and there will always be several in view from any point on the earth. The advantages are prompt detection and near-instantaneous position solution.





## Ground Segment

To receive the satellite downlink transmissions, a worldwide network of local user terminals (LUTs) is established. There are two types, GEOLUT for the geostationary satellites, and LEOLUT for the low earth orbit satellites. These are linked to mission control centres (MCCs) in various countries, and in turn to rescue coordination centres (RCCs). The closest MCC is in Canberra, co-located with RCC Australia, and RCCNZ is located in Avalon, Lower Hutt. New Zealand has two GEOLUTs and one LEOLUT, sited on a hilltop near Martinborough.

Development of the MEOSAR space segment requires the parallel establishment of a network of MEOLUTs, and it is envisaged that this system will become progressively operational from about 2015.

## Activation – Then What?

When a beacon is activated, the VHF transmission starts immediately, and the first valid 406 MHz data burst is sent about 50 seconds later. If the beacon is in sight of a GEOSAR satellite, the 406 signal will be relayed to GEOLUTs within coverage, thence to the associated MCC and RCC. Unless the beacon has GPS input, no position information will be available at this time, but the beacon identification will enable the RCC to at least start making appropriate enquiries.

When the beacon signal is received by a LEOSAR satellite, the SAR processor measures the Doppler shift in the

beacon frequency, time-tags the data, stores it in memory, and retransmits it continuously on the downlink to all LEOLUTs as they come into view. The extreme accuracy of the beacon frequency enables the position to be narrowed down initially to a 5-km radius, and subsequently to 2 km or less. With integral GPS information, the position accuracy is  $\pm 125$  metres. The data received by LEOLUT is relayed to MCC/RCC as for the GEOLUT.

» Where a beacon is out of GEOSAR line of sight due to terrain or other obstructions, chances are that the signal will still be detected by a LEOSAR satellite, because of its constantly changing position. Detection requires a satellite above a certain minimum angle of elevation, and in adverse circumstances, this could take some hours until a suitable orbit occurs.

## The Concept Isn't Perfect – Yet

Although the 406 MHz beacon system is a vast improvement, it does have limitations. It depends on a beacon signal being detected, and this in turn depends on the beacon surviving an accident and its antenna being in a position to radiate a usable signal. While this should be detected by GEOSAR, generating the initial alert, position information will be available only if there is a GPS associated with the beacon, and if not, only during a LEOSAR satellite pass. Activating an ELT in emergency while still airborne could

ensure that the signal is received in time and its approximate location determined, even if the beacon is later damaged.

There is a misconception in some quarters that all 406 MHz beacons include GPS – definitely not true. If purchasing an ELT for an aircraft that is already GPS equipped, it may be worth investigating an interface option, rather than an integral set. The main advantage here is that an interfaced ELT will transmit its last updated position without having to wait for an integral set to initialise. Another misconception is that 121.5 MHz is somehow 'obsolete'. Although satellites no longer detect 121.5/243 signals, 121.5 MHz is still the aeronautical international distress frequency, and should be monitored where appropriate.

Relying only on a beacon as your salvation is probably being over-optimistic. Other steps you can take beforehand will greatly enhance the probability of being found while it still counts – these include proper flight planning; filing a flight plan (when possible, you will be allocated an individual SSR code); reporting position regularly, particularly if deviating from plan; nominating a SARTIME; using a proprietary flight tracking system; and pre-briefing the contact nominated in your beacon registration details. Finally, these details must be up to date – changes must be notified, either by email to [406registry@maritimenz.govt.nz](mailto:406registry@maritimenz.govt.nz), or on line at [www.beacons.org.nz](http://www.beacons.org.nz). ■

# Artex G-switch Update

In the accelerated life-cycle testing, Artex has confirmed that the existing switches fail due to the combined effects of high humidity, salt-laden atmosphere, and vibration. The current switches are sealed, but not hermetically sealed. This means that they "breathe", leading in turn to oxidation and switch failure. Field failure data has confirmed that New Zealand has a much higher than average failure rate.

Artex has been looking for a replacement switch for some time, but this has proved to be rather elusive. Switches tested to date have either failed the complex accelerated

life-cycle testing, or have been found not to meet the accuracy requirements for ELT use.

A switch has now been identified that appears to meet all the requirements; it is a hermetically-sealed switch already in use in an approved ELT. There is still further testing required before the formal TSO approval process can be started.

The new switches could be available in the near future, but there is no firm date. Further information will be provided in *Vector* when known. ■

# Line Replaceable Unit (LRU)

Suppose your aircraft is broken and you need to get it back into the air as speedily as possible to deliver that urgent consignment. Don't panic, that unserviceable component that needs repairing, especially if it is avionics, may well be an LRU.

Many aircraft have components fitted for easy replacement on the flight line. These are LRUs, defined as modular aircraft components. They can normally be replaced quickly at operating locations, or line stations, by licensed aircraft maintenance engineers who are rated on the aircraft.

LRUs are usually enclosed modular, avionics units, electrical or instrument equipment. Some examples include: communications radios, in-flight entertainment systems, transponders, global positioning systems, automatic pilot modules, and flight management system units.

While the term LRU has been used for decades, an official recognised definition is, "An essential support item, which is removed and replaced at the field level to restore the end item to an operational ready condition." (MIL-PRF-49506, Notice 1 of 18 Jan 2005, *Performance Specification for Logistics Management Information*).

LRUs are designed to improve or speed up maintenance operations, because they can be stocked and replaced quickly from on-site inventory, restoring the system to service, while the unserviceable LRU is being repaired. Because the units are modular, they also reduce system costs and increase quality, by centralising development across different models of aircraft.

Ron Doggett, CAA Airworthiness Engineer (Avionics), says that modern aircraft, anywhere from small general aviation aircraft to airliners, are full of LRUs.

"Aircraft are increasingly becoming highly modular and integrated with

emerging technology. Any enclosed avionics modular equipment today can be an LRU.

"In its simplest form an unserviceable LRU, such as a communications radio box, is replaced with a serviceable unit, and the replacement unit is given a normal functional test, in accordance with the appropriate maintenance manual instructions."

## Words of Caution

Although simple replacement and function testing may apply in some cases, Ron cautions that increasingly, LRUs may also be part of highly integrated systems.

"In such cases, an LRU may need to be configured to interface correctly with other aircraft equipment in the installation, such as navigation, flight instrumentation, and autopilots, where substantial integration is necessary.

"The interface configuration of an LRU may be a manual task, but some installations now have a configuration module in the aircraft that carries the correct configuration to be loaded into the LRU. In these cases, a qualified avionics engineer would need to do the installation and integration checks to ensure that the set-up was configured correctly for the particular aircraft and its associated equipment."

Ron further cautions that where the Illustrated Parts

*Aircraft are increasingly becoming highly modular and integrated with emerging technology. Any enclosed avionics modular equipment today can be an LRU.*



Catalogue may give the correct hardware part number for the LRU, it will rarely provide the applicable software part number.

"Both the correct hardware and software are required. The software in many cases can be loaded into the aircraft system on the line, as with the LRU. The aircraft owner or operator is responsible for the configuration management of the aircraft and for ensuring that the correct software for each aircraft is loaded."

AC 91-18, *Aircraft Software Configuration Management*, provides information on configuration management.

## How Do I Recognise One?

They will normally be installed to facilitate quick and easy replacement, such as in avionics racks, but you must check the aircraft maintenance manual to be sure. The maintenance manual will also contain the necessary installation and checking instructions, as well as any other required information.

## Prerequisites

To replace an LRU, you will need to be an appropriately licensed aircraft engineer and be familiar with the specific aircraft and component being maintained. As the holder of an aircraft maintenance engineer licence in either the aeroplane or rotorcraft categories, you may replace an LRU, provided you are rated on the aircraft type and are familiar with the component.

Ron cautions, "With integrated systems however, an avionics engineer may be the only one who can do the job properly."

## Learn More

Read the applicable aircraft and component maintenance manuals

Part 66 Appendix C, *Additional Privilege*

AC 66-1 *Aircraft Maintenance Engineer Licence – General*

AC 91-18 *Aircraft Software Configuration Management*

AC 43-15 *Aircraft Software Configuration Management* ■

Ron Doggett, CAA Airworthiness Engineer (Avionics).

# New Authority Member



Aviation professional Grant Lilly has joined the board of the Civil Aviation Authority. He has an extensive background in airline management, including 30 years at Air New Zealand, where Mr Lilly became General Manager of the International Airline business unit.

He later joined Qantas where he established Jetconnect, and then became Qantas' overall General Manager for New Zealand and the Pacific Islands. Mr Lilly this year decided to move from senior executive roles to focus on

governance roles full time. He currently sits on the Auckland Regional Amenities Funding Board, and the board of the Tourism Industry Association.

Mr Lilly is a strong advocate for the Safety Management System (SMS) framework for managing aviation safety.

"There's a perception that SMS is something totally new and different. It isn't. It's about lifting the bar so that safety becomes the number one priority of every employee and every aspect of the organisation, not just the concern of the nominated senior people like the Chief Pilot and the Quality Assurance Manager," Mr Lilly says.

"SMS entails a whole of business approach. It means more intensive activities and frameworks for risk management and risk assessment, and for business continuity planning, as opposed to just managing operational safety and performance."

He says the preventative focus of SMS does not change the work that certificated operators are already doing to manage operational safety.

"That work is the foundation of SMS. This is not about changing everything we've already got. It's about lifting the bar and building on what's already in place, to provide a 'whole of organisation' focus for safety in its widest context." ■

## Director to Step Down

Director of Civil Aviation Steve Douglas will step down from his role in April 2012. Steve announced his decision to resign in a message to staff in September.

Steve has worked for the CAA for 24 years, holding a number of senior management positions in that time. He was appointed Director of Civil Aviation in June 2007. In his message to staff he said the Director/CEO role had been both challenging and satisfying.

"There has been significant growth in aviation activity in New Zealand during my time as Director, including new airlines, technological advances, and new uses for aircraft. The CAA has responded to these challenges while achieving improved safety and a downward trend in the overall accident rate. The safety performance of our airline sector rates with the best in the world."

Steve will continue to lead the organisation, providing continuity in the role while the search for a replacement is made.

"This is a good time for me to go", Steve says.

"There are things that I want to see and do, and I expect this will keep me in aviation after April 2012." ■

# Keeping Threats and Errors on the Radar

“Instructing is a very unforgiving environment when things go wrong. Instructors should take every opportunity to be prepared for dealing with issues and keeping up to date,” says A-Category instructor, Tim Maynard, who attended the Auckland Flight Instructor seminar.

The CAA conducts these seminars biennially. The 2011 seminars were held in Auckland, Wellington and Christchurch, and focused on Threats and Errors.

Tim Maynard says he got a lot out of the presentation on Unmanned Aircraft Systems (UAS) Threats and Errors, by the CAA’s Sport and Recreation Manager, Rex Kenny.

“This presentation made me appreciate the importance of keeping up with NOTAMs and warnings about UAS operations.”

Jim Wilson, Group Chief Pilot for Helicopters NZ, who attended the Wellington seminar, agrees.

“Adherence to NOTAMs when flight planning is well-documented in our operational procedures and checklists, but even so, attending the seminar was an opportunity to highlight this again to our company pilots. It was an eye-opener to see how many incidents and airspace violations were a direct result of NOTAMs not being reviewed prior to flight.”

Otago Aero Club instructor, Joe Calder, who was at the Christchurch seminar, says, “One of the most useful things I’ve taken away from the seminar is learning how to apply Threat and Error Management (TEM) practically.”

C-Category flight instructor Andrew Love, who teaches aerobatics, says, “Before attending the Christchurch seminar, I knew my students were a risk in the flight training environment, but never thought of them as a major threat. You need to brief your student (and yourself) on what you will do if they are unable to complete a manoeuvre themselves – even if you are instructing someone who is a very experienced pilot in their own right.”

The seminar segment on the application of TEM in both fixed and rotary wing, included presentations by assessors and instructors.

Tim Maynard was also appreciative of a presentation on Hazardous Attitudes by the CAA’s Senior Medical Officer, Dr Claude Preitner.

“Knowing how to deal with individuals with potentially hazardous attitudes is an important area that needs to be developed as part of the Flight Instructor skill set,” says Tim.

These seminars included other presentations on accidental threats in flight instruction, mountain training progress check, and airspace and aerodrome threats.

The seminars were also a chance for flight instructors to network.

Jim Wilson says, “We have a tendency to be immersed in our own particular areas of the industry, and at times, lack awareness of other issues that have arisen. It was interesting to hear how other operators and flight training organisations on the course addressed the same issue.”

Tim Maynard says, “These seminars give you the opportunity to keep up with current developments, as it is easy to get left behind. Everyone should be encouraged to attend.”

More than 150 instructors attended the seminars this year.

Seminar organiser and CAA Flight Testing Officer, John Parker, says, “It’s always encouraging to experience the enthusiasm of young instructors. These seminars give the CAA renewed confidence that instructors take their responsibility seriously.”

The seminar papers are available on the CAA web site, under “Seminars and Courses”. ■

# Squawk for Safety

## Why you should keep your transponder on outside transponder mandatory airspace

All controlled airspace in New Zealand is transponder mandatory (TM), as well as the upper portion of some Mandatory Broadcast Zones in Class G airspace. It is safest for everyone, however, if you keep your transponder on ALT at all times – not just in TM airspace.

## Collision Avoidance

Transponders produce a response when they receive a radio-frequency interrogation from either secondary surveillance radar (SSR), or ACAS/TCAS equipped aircraft. It is essential to have your transponder on in Class G airspace, even if you know you are outside SSR coverage, so that aircraft with ACAS/TCAS can see you on their screen. With ALT selected, your position and altitude relative to the ACAS/TCAS aircraft will be displayed, giving the pilot a good idea of where to start looking, in order to find you visually.

Before an IFR aircraft leaves controlled airspace, or before they take off from an uncontrolled aerodrome, ATC or Christchurch Information pass information on to them about known IFR traffic in the area. To further assist the IFR pilot's situational awareness, ATC may also pass on information about VFR traffic on their screen. VFR traffic will be described as "unverified". This is particularly helpful for IFR pilots who do not have ACAS/TCAS, and another good reason to keep your transponder switched to ALT at all times.

## In Case of Emergency

In SSR coverage, if you file a flight plan and squawk your allocated code, you will leave a trail that will narrow down the search area if you were to go missing. Should the worst happen, your transponder transmissions can be made into a radar track plot to see your movements.

It is important to squawk the code given to you in your flight plan, or the aircraft's own discrete code, if allocated, because

there could be dozens of other aircraft squawking 1200 or 1500 – making it very difficult to figure out which one you are.

If your transponder is on, and an emergency situation develops, one less step will be required at a very high workload moment, should you need to squawk an emergency code (7700 for emergency, 7600 for loss of radio communication, or 7500 for unlawful interference). Some older types of transponder take time to warm up. You cannot turn these models on and expect them to transmit instantly. Older transponders may not produce a signal for at least a minute – this is a long time in an emergency situation.

Keeping your transponder on also helps if you become disoriented, lost, or inadvertently caught between cloud layers. In this situation, contact the Flight Information Service. They will ask you to squawk 7700 and request your last known position. If you are within SSR coverage, you will flash red and yellow on their screen. They can then hand you over to a radar controller to help you get back on track.

If your SARTIME goes overdue, the Flight Information Service have 15 minutes in which to check if you have arrived at your destination, or otherwise make contact with you, before they contact the Rescue Coordination Centre. Looking for your allocated SSR code on screen is one of the methods they use. If you are within SSR coverage, and you have forgotten to update the SARTIME in your flight plan, they will be able to see if you are still flying.

## Normal Operations

Within SSR coverage, it will be easier to get a controlled VFR clearance into a control area, or entry into a control zone if you are squawking your allocated code and you refer to it when you request a clearance from ATC. This will enable the controller to see exactly who you are and where you are when you contact them – making it quicker and easier for the controller to determine if your request can be granted.

An SSR coverage map can be found in *AIP New Zealand*, ENR 1.6 – 5.1.2. ■



# Bilateral Partners' Meeting

In 2012, the CAA is co-hosting the FAA/Asia Pacific Bilateral Partners' Meeting in Wellington, 27 to 29 March. Delegates participate from all Asia Pacific countries that have, or are working towards, a Bilateral Aviation Safety Agreement with the United States, or have significant aviation safety interests in the region.

The first two days are for the regulators, but the third day is set aside for the local aviation industry to participate in open dialogue with the Authorities. Take advantage of this Industry Day, when you can pose questions regarding regional safety regulatory issues.

See the web site below for more information and to register. We'll also have an update in the next issue of *Vector*. ■



CIVIL AVIATION AUTHORITY  
OF NEW ZEALAND  
*Te Mana Rererangi Tūmatanui o Aotearoa*

27 to 29 March 2012

**Industry Day 29 March**

Amora Hotel, Wellington, New Zealand

To register, and for all info, see:

[www.caa.govt.nz/bilateral](http://www.caa.govt.nz/bilateral)



## CAA Safety DVDs

Our safety videos are great for refreshing awareness on a number of flying topics. Here's a few examples:

**M**ountain Flying will help pilots visualise essential mountain flying concepts before they begin training with an appropriately qualified instructor. Filmed in the Wanaka, Queenstown, and Milford Sound areas, and packed full of spectacular air-to-air and in-cockpit footage, this DVD shows you actual mountain flying, as it is happening, from multiple perspectives.

*Safety Around Helicopters* provides general safety information for anyone who operates around helicopters. There's an Introduction with general information for everyone, and then modules titled: Going Bush, The Mountains, Industry, All at Sea, Corporate & Tourism, and Rescue on the Land, specifically on those topics.

If you plan your flying to skirt around controlled airspace, then *VFR in Controlled Airspace* is a 'must see'. It debunks the idea that flying in controlled airspace is complicated or intimidating. You will hear a friendly Air Traffic Controller explain procedures for a flight, and two young pilots discuss the issues and fly the route.

See the full list of safety DVDs on the CAA Web Site, [www.caa.govt.nz](http://www.caa.govt.nz), "Safety Info – CAA Safety DVDs". You can borrow them from the CAA library, and you can purchase them from Video NZ, [www.videonz.co.nz/dvd\\_sales\\_NZ.html](http://www.videonz.co.nz/dvd_sales_NZ.html). ■



# IA Renewal Course

The Certificates of Inspection Authorisation (IA) held by Licensed Aircraft Maintenance Engineers (LAMEs) come up for renewal every five years. You can renew by attending the CAA's IA renewal course. Here are the course dates for 2012.

**The CAA will run four IA renewal courses during February – March 2012.**

Christchurch	20, 21 February
Queenstown	1, 2 March (during the AIA/AEANZ training week)
Palmerston North	19, 20 March
Auckland	26, 27 March

See the CAA web site, [www.caa.govt.nz](http://www.caa.govt.nz), under "Seminars and Courses", for more information, and to suggest topics for the course. Email: [mark.boyle@caa.govt.nz](mailto:mark.boyle@caa.govt.nz). ■

## National Airspace and Air Navigation Plan

The CAA is leading development of the National Airspace and Air Navigation Plan and there's a new web page for it on the CAA web site, [www.caa.govt.nz](http://www.caa.govt.nz). The link is on the home page.

The Plan will cover a number of different areas of work: airspace; communications, navigation and surveillance/air traffic management (CNS/ATM); aeronautical information; meteorological information; and aerodromes. Each area of work will further consider implications such as: aircraft, licensing and training requirements; regulatory requirements; and environmental, efficiency, and security considerations. ■

## Aviation Safety Advisers

Aviation Safety Advisers are located around New Zealand to provide safety advice to the whole aviation community. You can contact them for information and advice.

### Don Waters (North Island)

Tel: +64 7 376 9342  
 Fax: +64 7 376 9350  
 Mobile: +64 27 485 2096  
 Email: [Don.Waters@caa.govt.nz](mailto:Don.Waters@caa.govt.nz)

### John Keyzer (Maintenance, North Island)

Tel: +64 9 267 8063  
 Fax: +64 9 267 8063  
 Mobile: +64 27 213 0507  
 Email: [John.Keyzer@caa.govt.nz](mailto:John.Keyzer@caa.govt.nz)

### Murray Fowler (South Island)

Tel: +64 3 349 8687  
 Fax: +64 3 349 5851  
 Mobile: +64 27 485 2098  
 Email: [Murray.Fowler@caa.govt.nz](mailto:Murray.Fowler@caa.govt.nz)

### Bob Jelley (Maintenance, South Island)

Tel: +64 3 322 6388  
 Fax: +64 3 322 6379  
 Mobile: +64 27 285 2022  
 Email: [Bob.Jelley@caa.govt.nz](mailto:Bob.Jelley@caa.govt.nz)

## How to Get Aviation Publications

### AIP New Zealand

AIP New Zealand is available free on the internet, [www.aip.net.nz](http://www.aip.net.nz). Printed copies of Vols 1 to 4 and all **aeronautical charts** can be purchased from Aeronautical Information Management (a division of Airways New Zealand) on 0800 500 045, or their web site, [www.aipshop.co.nz](http://www.aipshop.co.nz).

### Pilot and Aircraft Logbooks

These can be obtained from your training organisation, or 0800 GET RULES (0800 438 785).

### Rules, Advisory Circulars (ACs), Airworthiness Directives

All these are available free from the CAA web site. Printed copies can be purchased from 0800 GET RULES (0800 438 785).

## Planning an Aviation Event?

If you are planning any aviation event, the details should be published in an *AIP Supplement* to warn pilots of the activity. For *Supplement* requests, email the CAA: [aero@caa.govt.nz](mailto:aero@caa.govt.nz).

To allow for processing, the CAA needs to be notified at **least one week** before the Airways published cut-off date.

Applying to the CAA for an aviation event under Part 91 does not include applying for an *AIP Supplement* – the two applications must be made separately. For further information on aviation events, see AC91-1.

CAA Cut-off Date	Airways Cut-off Date	Effective Date
19 Dec 2011	2 Jan 2012	8 Mar 2012
24 Jan 2012	30 Jan 2012	5 Apr 2012
20 Feb 2012	27 Feb 2012	3 May 2012

See [www.caa.govt.nz/aip](http://www.caa.govt.nz/aip) to view the *AIP* cut-off dates for the year 2012.

## Aviation Safety & Security Concerns

Available office hours (voicemail after hours).

**0508 4 SAFETY**  
 (0508 472 338)

[isi@caa.govt.nz](mailto:isi@caa.govt.nz)

For all aviation-related safety and security concerns

## Accident Notification

24-hour 7-day toll-free telephone

**0508 ACCIDENT**  
 (0508 222 433)

[www.caa.govt.nz/report](http://www.caa.govt.nz/report)

The Civil Aviation Act (1990) requires notification "as soon as practicable".

# Accident Briefs

More Accident Briefs can be seen on the CAA web site, [www.caa.govt.nz](http://www.caa.govt.nz), "Accidents and Incidents". Some accidents are investigated by the Transport Accident Investigation Commission, [www.taic.org.nz](http://www.taic.org.nz).

## ZK-HQD Robinson R22 Beta

Date and Time:	14-Jan-11 at 18:00
Location:	Otago
POB:	2
Injuries:	0
Damage:	Substantial
Nature of flight:	Private Other
Pilot Licence:	CPL (Helicopter)
Age:	26 yrs
Flying Hours (Total):	790
Flying Hours (on Type):	615
Last 90 Days:	15

The pilot and a passenger were undertaking a private flight on the passenger's high country station in Central Otago. The helicopter was being operated at a high all-up weight, with a pressure altitude at the accident site of 5,600 feet. As the helicopter was manoeuvred downwind, a low rotor RPM situation developed. As the rotor RPM decreased the helicopter began to sink. Without sufficient height above the ground, or an escape route available, the pilot had no choice but to let the helicopter contact the ground. The helicopter rolled over and suffered major damage. Neither the pilot nor passenger was injured.

[CAA Occurrence Ref 11/127](#)

## ZK-HSP Bell (HH) UH-1H

Date and Time:	28-Feb-11 at 9:08
Location:	Hokio Beach
POB:	1
Injuries (Serious):	1
Damage:	Substantial
Nature of flight:	Ferry/Positioning
Pilot Licence:	CPL (Helicopter)
Age:	60 yrs
Flying Hours (Total):	20800
Flying Hours (on Type):	3000
Last 90 Days:	105

The pilot noticed that the engine oil pressure was fluctuating and decided to carry out a precautionary landing on a nearby beach. Prior to landing, a total engine failure occurred which resulted in a very heavy landing and roll over.

The CAA carried out a safety investigation which determined that the number one compressor bearing had failed resulting in a total engine failure. The failed bearing was sent to Honeywell for metallurgical examination, however, due to the extensive damage to the bearing, a cause for the bearing failure could not be determined.

[CAA Occurrence Ref 11/830](#)

## ZK-KTN Australian Av Works Kararoo J6 C

Date and Time:	22-May-11 at 14:30
Location:	Middlemarch
POB:	2
Injuries:	0
Damage:	Substantial
Nature of flight:	Private Other

The undercarriage collapsed during a precautionary landing, causing damage to the propeller. The pilot felt the strength of the undercarriage was inadequate.

[CAA Occurrence Ref 11/2334](#)

## ZK-EWU Micro Aviation Bantam B22S

Date and Time:	5-Feb-11 at 15:05
Location:	Ngahinapouri
POB:	1
Injuries:	0
Damage:	Substantial
Nature of flight:	Private Other
Age:	68 yrs
Flying Hours (Total):	1335
Flying Hours (on Type):	402
Last 90 Days:	3

While on approach, a total loss of engine power occurred when the pilot attempted to increase power. The aircraft landed short of the strip, touched down heavily and ran into a ditch. The nose and right hand main undercarriage separated from the aircraft during the landing sequence. The mixture control was found to have been left in the lean cruise setting.

[CAA Occurrence Ref 11/439](#)

## ZK-EYC Piper PA-38-112

Date and Time:	9-Jun-11 at 10:30
Location:	Rangiora
POB:	1
Injuries:	0
Nature of flight:	Training Solo
Pilot Licence:	PPL (Aeroplane)
Age:	28 yrs
Flying Hours (Total):	113
Flying Hours (on Type):	34
Last 90 Days:	58

During taxi operations the left wing contacted a fence post.

[CAA Occurrence Ref 11/2818](#)



### ZK-HHG Hughes 369D

Date and Time:	28-Feb-11 at 11:15
Location:	Wairoa
POB:	1
Injuries:	0
Damage:	Minor
Nature of flight:	Ferry/Positioning
Pilot Licence:	CPL (Helicopter)
Age:	33 yrs

After finishing a morning of spraying, the pilot returned to pick up his loader driver from the loading site. On approach to the loading site, the pilot momentarily lost situational awareness of the 11 kV wires and turned into them. The helicopter received damage to the main rotor blades and perspex. Fortunately, a wire cutter was installed.

[CAA Occurrence Ref 11/836](#)

### ZK-GB0 Schempp-Hirth Duo Discus T

Date and Time:	29-Jan-11 at 13:30
Location:	Omarama
POB:	2
Injuries:	0
Damage:	Substantial
Nature of flight:	Training Dual
Pilot Licence:	CPL (Glider)
Age:	64 yrs
Flying Hours (Total):	6581
Flying Hours (on Type):	146
Last 90 Days:	154

The glider was being aero-tow launched. During the crosswind takeoff, the tow plane started drifting to the right and departed the vector. At this stage the glider tow rope was released but the glider continued to follow the same trajectory and struck a mound of dirt heavily, breaking into three separate sections.

[CAA Occurrence Ref 11/365](#)

### ZK-VDB Sonex Ltd Sonex

Date and Time:	15-Mar-11 at 9:29
Location:	Dargaville Aerodrome
POB:	1
Injuries (Serious):	0
Damage:	Substantial
Nature of flight:	Private Other
Age:	65 yrs
Flying Hours (Total):	142
Flying Hours (on Type):	55
Last 90 Days:	23

The pilot misjudged the touchdown position and hit a fence post with the front wheel during the flare. The pilot reported that forward vision over the engine cowling was limited, due to the high nose attitude of the aircraft.

[CAA Occurrence Ref 11/1080](#)

### ZK-BJX Cessna 180

Date and Time:	23-Feb-11 at 14:06
Location:	New Plymouth
POB:	1
Injuries:	0
Nature of flight:	Private Other
Pilot Licence:	PPL (Aeroplane)
Age:	55 yrs
Flying Hours (on Type):	100
Last 90 Days:	20

The C180 was taxiing for takeoff when ATC instructed the pilot to hold, just before turning to line up. The aircraft was therefore at right angles to the wind when a stronger gust lifted the tail, tipping it onto the nose and left wingtip. The pilot was aware of the potential consequences of taxiing in strong winds and was using appropriate control inputs, however the sudden gust caught him out before he could react to it.

[CAA Occurrence Ref 11/1226](#)

### ZK-PPA Piper PA-25-235

Date and Time:	29-Jan-11 at 13:30
Location:	Omarama
POB:	1
Injuries:	0
Nature of flight:	Towing
Pilot Licence:	PPL (Aeroplane)
Age:	62 yrs
Flying Hours (Total):	3300
Flying Hours (on Type):	10
Last 90 Days:	61

The aircraft was involved in aero-tow launching of gliders. During the takeoff roll in a strong crosswind, the aircraft drifted to the right and departed from the runway. The glider being towed was released as the aircraft vacated the runway. It then entered an area of long grass and hit a small bank of earth causing the left undercarriage to collapse.

[CAA Occurrence Ref 11/367](#)

### ZK-MSS Rans S-6ES Coyote II

Date and Time:	27-Apr-11 at 4:00
Location:	Greenfield
POB:	1
Injuries:	0
Damage:	Minor
Nature of flight:	Private Other
Flying Hours (Total):	346
Flying Hours (on Type):	163
Last 90 Days:	29

While landing downhill in long wet grass on a private farm strip, the aircraft nosed over at the end of the landing rollout.

[CAA Occurrence Ref 11/1862](#)

# GA Defects

GA Defect Reports relate only to aircraft of maximum certificated takeoff weight of 9000 lb (4082 kg) or less. More GA Defect Reports can be seen on the CAA web site, [www.caa.govt.nz](http://www.caa.govt.nz), "Accidents and Incidents".

## Key to abbreviations:

<b>AD</b> = Airworthiness Directive	<b>TIS</b> = time in service
<b>NDT</b> = non-destructive testing	<b>TSI</b> = time since installation
<b>P/N</b> = part number	<b>TSO</b> = time since overhaul
<b>SB</b> = Service Bulletin	<b>TTIS</b> = total time in service

## Alpha R2160

### Alternator

Part Manufacturer:	Alpha
ATA Chapter:	2420
TSO hours:	2268
TTIS hours:	2268

The pilot reported that the alternator was not supplying current in flight. During maintenance investigation, the engineer carried out a ground run of the aircraft and confirmed the fault, noting that when the alternator came on line it was uncontrollable and the only way to turn off the alternator was to stop the engine. It was discovered that the alternator field wire had chafed and shorted against the alternator output terminal resulting in the output from the alternator becoming uncontrollable.

The field wire was repaired and routed clear of the output terminal. The severe over-voltage had caused damage to the voltage regulator, two engine gauges, and the warning panel, all of which had to be repaired or replaced. The operator's fleet of six Alphas were inspected and two others were showing signs of the field wire starting to wear in the same area.

In response to this defect, Alpha Aviation have produced and distributed Service Letter AA-SL-24-001 Alternator Cable Inspection. The service letter recommends that during the next maintenance visit, the cables at the rear of the alternator be inspected for correct routing, support, and that there are no signs of taut, distressed, or chafed cables.

CAA Occurrence Ref 11/2303

## Britten-Norman BN2A-26

### Governor

Part Manufacturer:	Woodward
Part Number:	G210659
ATA Chapter:	6120
TSI hours:	3.5
TSO hours:	1871.4

During takeoff, the aircraft's left engine suffered a significant loss of power. The takeoff was not able to be aborted, so a gradual climb, followed by a landing on the opposite vector was carried out. Maintenance investigation found that the left hand propeller constant speed unit driveshaft had sheared causing the propeller to feather. The governor was sent to an overhaul facility for further

investigation, however, the cause of the driveshaft failure could not be determined.

CAA investigation, in consultation with the manufacturer Ontic Engineering, determined that it was possible that the drive gear was an older version which had a finite life of 4600 hours in accordance with Woodward Service Bulletin 33539C Supplement No.1. The failed drive gear had completed approximately 5770 hours TTIS. Newer drive gears have a service life of four overhaul periods, as specified by Woodward Service Bulletin 33531C. The overhaul period is deemed to be the same as that of the engine to which the governor is fitted.

CAA Occurrence Ref 11/617



## Cessna 206

### Oil drain

Part Model:	IO 520 A32B
Part Manufacturer:	Continental
ATA Chapter:	7900
TSO hours:	10.3
TTIS hours:	9.5

During a scenic flight at 10,000 feet, the pilot noticed a loss of oil pressure and falling oil temperature. He immediately initiated a descent and return to the aerodrome. The engine subsequently seized on the landing roll. Maintenance investigation found that the engine had lost all lubricating oil and had seized, and the sump oil drain fitting was missing. The engine was a factory re-manufactured item which had been installed in the aircraft approximately 10 hours prior to the incident. The maintenance organisation involved with fitting the engine carried out an internal investigation. The investigation determined that the oil drain fitting had been transferred from the old engine to the newly installed engine. The fitting should have been sufficiently tightened and lock wired in place, there was no trace of lockwire in the engine sump boss. At the conclusion of the company investigation, it was determined that adequate controls were in place and the certifying engineer is ultimately responsible for carrying out a final inspection.

CAA Occurrence Ref 11/12

## Cessna A152

### Elevator trim tab chain

Part Number:	S2295P25-69
ATA Chapter:	2732
TTIS hours:	9003.2

The elevator trim cables were removed for replacement. As the chain was cleaned and inspected for re-installation, nine cracks were found in the side links of the chain. This type of chain is common in most Cessna aircraft. The maintenance provider was unable to determine the cause for the cracked chain links but suspects they could be due to age and corrosion. It is also possible that the chain may have been contaminated with paint stripper at an earlier time, which may have caused hydrogen embrittlement. The chain was replaced.

[CAA Occurrence Ref 11/2632](#)

## Tecnam P92 Echo Super

### Mass balance

Part Manufacturer:	Tecnam
Part Number:	P92-JS/Echo Super
ATA Chapter:	5540
TTIS hours:	606.4

When the fin tip was removed during maintenance activity, it was found that the rudder mass balance was very loose where it mounted on the rudder. This allowed the balance weight to move approximately 1.5 inches side to side. The rudder mass balance attaches to the rudder top bush and is pinned with a 4 mm bolt. The bolt holes had become slotted and the bolt was bent. The hole was reamed to accept a 3/16 NAS bolt which was torqued to a considerably higher value than the previous soft 4mm bolt. CAA enquires with the manufacturer indicated that they were not aware of any other previously reported defects of this nature.

[CAA Occurrence Ref 11/770](#)

## Jodel D.11

### Cylinder exhaust valve

Part Model:	C908F-3
Part Manufacturer:	Continental
ATA Chapter:	8530
TSO hours:	470
TTIS hours:	1093

While in the cruise, 10 NM west of NZRO and on track for NZMA, the pilot heard a bang and then felt a vibration from the engine. He diverted to NZRO and transmitted a PAN PAN call. The engine continued to run, but with a considerable power loss. The pilot was able to reach NZRO and land safely. The engine stopped after landing when the throttle was closed, it was able to be restarted, however, and the pilot taxied the aircraft to the hangar.

Maintenance investigation found that the number one exhaust valve head had detached and become embedded in the top of the piston. The engine was last overhauled in 1994, when two of the exhaust valves were replaced. It is likely that the failed valve was not replaced in 1994, and that the effect of time in service is a factor. As a precautionary measure, the owner has decided to carry out a top overhaul of the engine including new pistons and valves.

[CAA Occurrence Ref 11/2412](#)

## Cessna U206G

### Engine through bolt

Part Model:	I0520-F
Part Manufacturer:	Teledyne continental
Part Number:	641931-9.81
ATA Chapter:	8500
TTIS hours:	175.5

During a scheduled 200-hour inspection, the front lower through bolt securing the number six cylinder was found broken. Initially the through bolt was replaced, and the other bolts and studs in the area were re-torqued. The oil filter was checked after 15 hours to ensure that the front bearing had not spun. The engine is a TCM remanufactured unit. The manufacturer examined photos of the failed bolt and suspects hydrogen embrittlement to be the cause of failure. The manufacturer advised that all through bolts required replacement.

[CAA Occurrence Ref 11/1044](#)

## Hughes 369D

### Main rotor blade

Part Manufacturer:	Helicopter Technology Company
Part Number:	500P2100-101
ATA Chapter:	6210
TSI hours:	78.5
TTIS cycles:	14065
TTIS hours:	2195.5

During a pre-flight inspection, a 100 mm crack was found in the skin on the blade underside. Scheduled maintenance five hours previously did not detect any anomalies. A torque event inspection had been carried out 13.6 hours previously as a result of a torque event. It is possible that the cracking was initiated by the torque event. The main rotor blades were replaced.

[CAA Occurrence Ref 11/361](#)

## Robinson R44 II

### Motor

Part Model:	PE2002 1R
Part Manufacturer:	Weldon
Part Number:	8850-7
ATA Chapter:	2820
TTIS hours:	362.1

The auxiliary fuel pump light illuminated in flight and the pump circuit breaker tripped. The pilot landed the helicopter and sought engineering assistance. The fuel pump assembly was removed from the helicopter. The motor was removed from the pump and disassembled. The armature support bearing was found to be dry and rough running. The engineer suspects that the electric motor is inadequate for its purpose, and is aware of numerous failures of these motors due to brushes wearing too quickly and/or bearing failures. This pump assembly was only installed in April 2010 as a replacement for a previous motor failure at 221.7 TTSN. The pump assembly was replaced as the motor is not a procurable item from RHC. Although the pump assembly is manufactured by Weldon, the electric motor appears to be a commercially available import.

[CAA Occurrence Ref 11/1328](#)

# Summer Traffic Busy Spots

Don't inadvertently fly into an aviation event – check your *AIP New Zealand Supplements* for planned events near you. If you don't subscribe personally, you can download the *AIP Supplements* for free from [www.aip.net.nz](http://www.aip.net.nz).

This map shows the known flying events between late November 2011 and mid-March 2012.

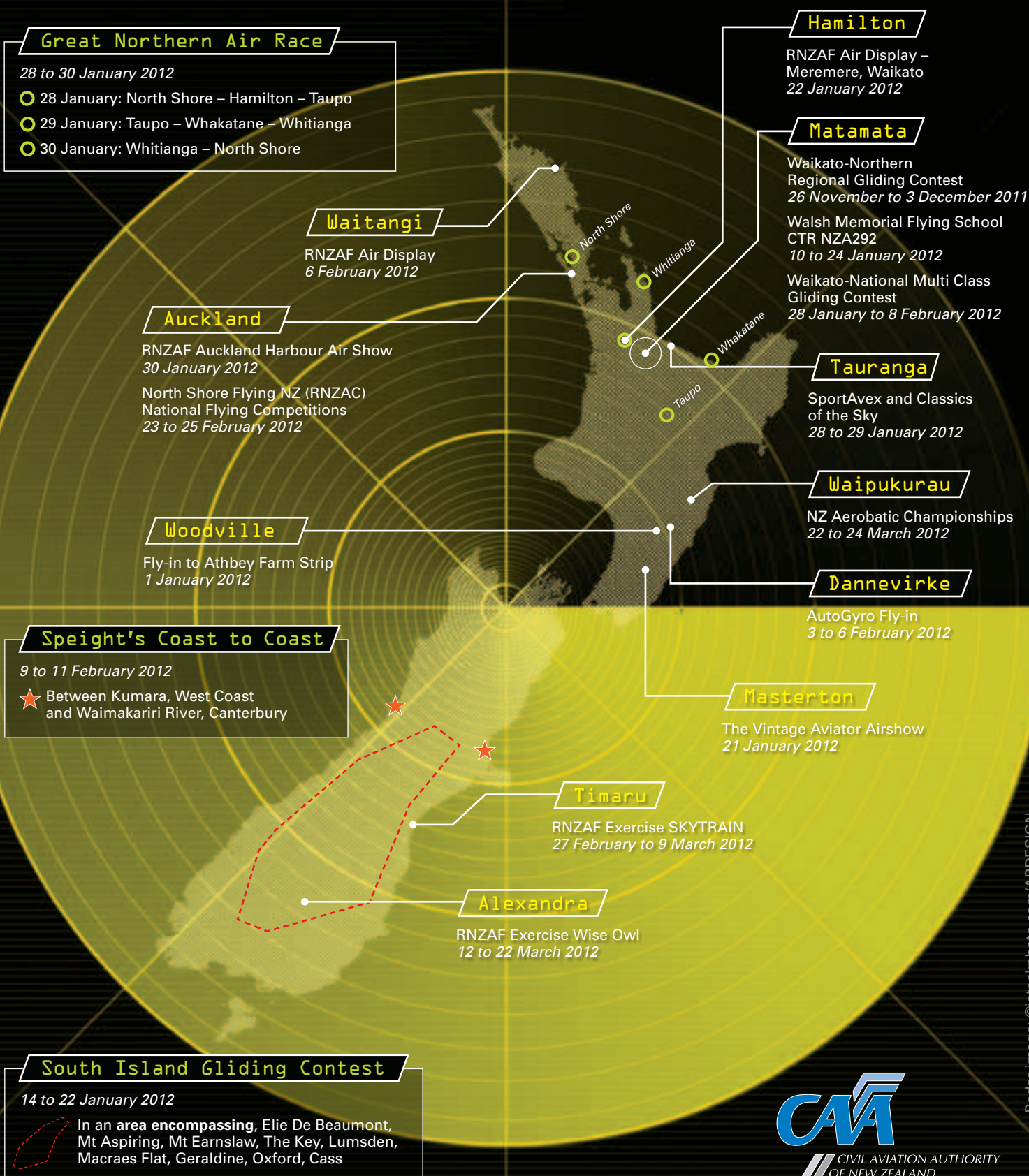

Radar image: ©istockphoto.com/ABDESIGN



Keep these events on your radar